

Note:

ASME stamped vessels 36" Dia. and smaller require (2) Inspection Openings. 42" Dia. and larger require a 12"x16" Manhole. Vessels with an internal lining also require a manhole.

\*DRAWING SHOWS GENERAL ARRANGEMENT ONLY. ALL FITTING SIZES AND LOCATIONS ARE SUBJECT TO CHANGE TO MEET CUSTOMER SPECIFICATIONS.

### HYDRO-PNEUMATIC TANK (VERTICAL)

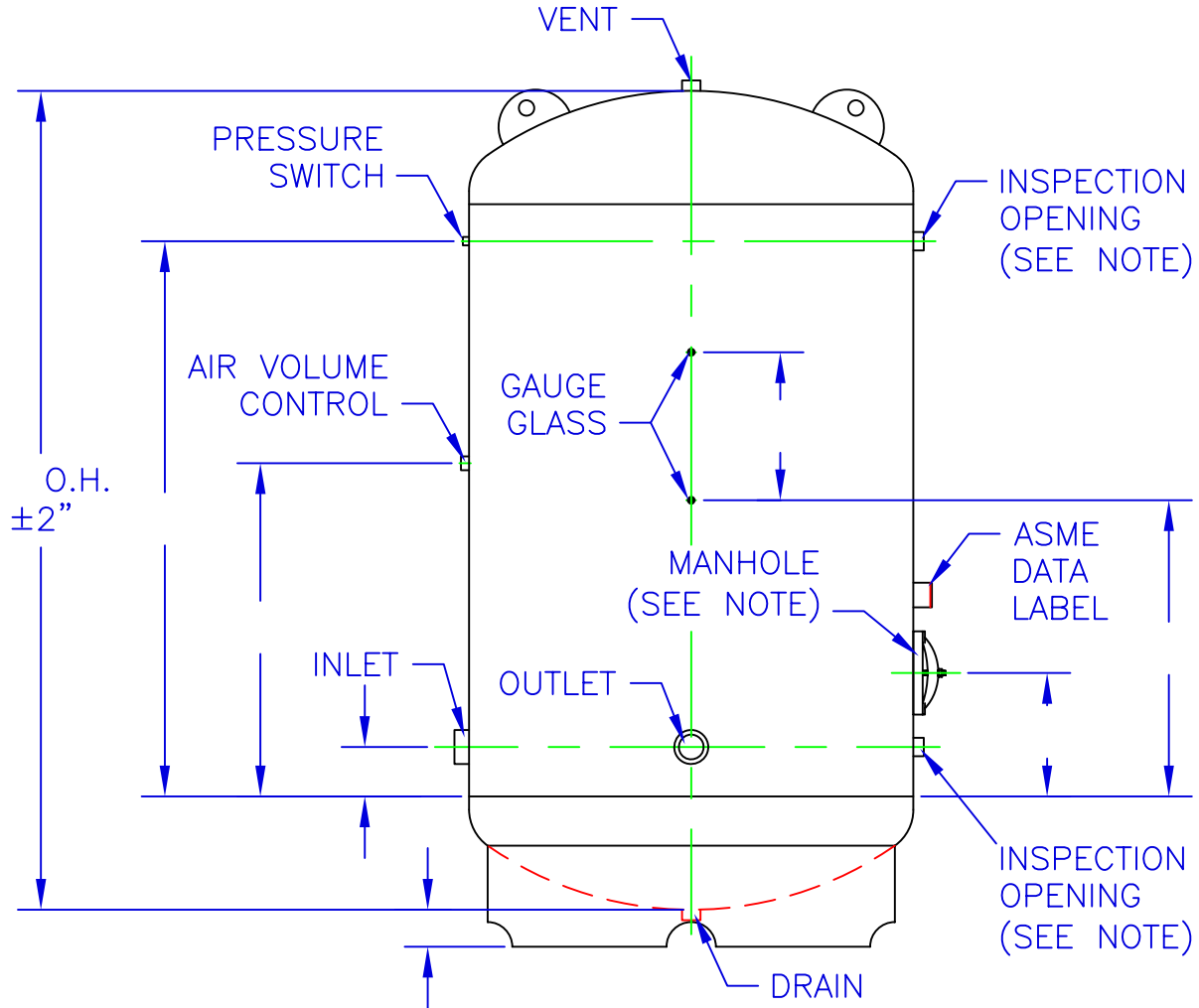
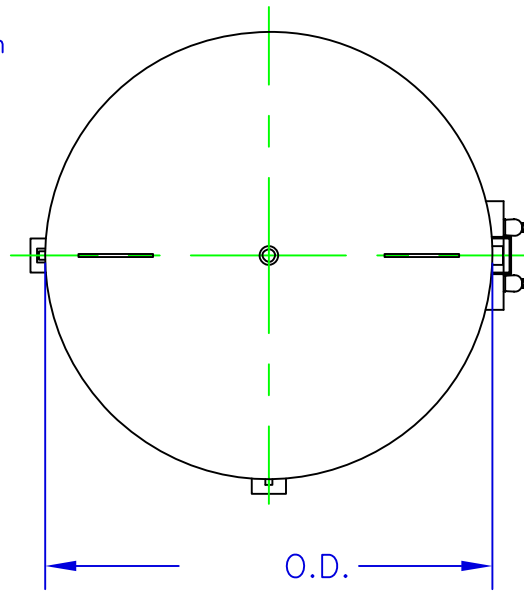

## Wheeler Tank Manufacturing, Inc.

4001 N. 4th Avenue - Sioux Falls, SD 57104  
Phone: 605-332-2012 - Fax: 605-332-3222 - 1-800-888-9526  
www.wheelertank.com